

FLEXIBLE COUPLINGS RUPEX SERIES

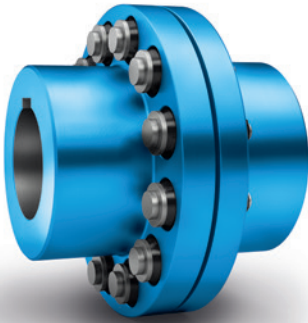

General	8/3
Benefits	8/3
Application	8/3
Design and configurations	8/4
Function	8/6
Technical specifications	8/6
<hr/>	
Type RWN – Hub material grey cast iron	8/8
Type RWS – Hub material steel	8/10
Type RFN – Hub material grey cast iron	8/12
Type RFS – Hub material steel	8/14
Type RWB – with brake disk to DIN 15432	8/16
Type RBS – with brake disk to DIN 15432	8/18
Type RBS – with brake disk to DIN 15432	8/20
Type RWB – with brake drum to DIN 15431	8/22
Type RBS – with brake drum to DIN 15431	8/23
Spare and wear parts	8/24



RUPEX

FLENDER



GENERAL

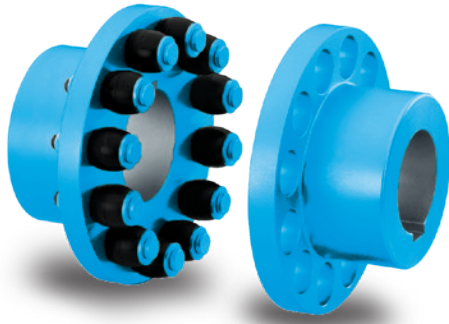

Coupling suitable for use in potentially explosive atmospheres.

Complies with the current ATEX Directive for:

CE Ex II 2G Ex h IIC T6 ... T4 Gb X

Ex II 2D Ex h IIIC T85 °C ... 110 °C Db X

Ex I M2 Ex h Mb X

RUPEX pin and bush couplings link machine shafts and compensate for shaft misalignment with weak restorative forces.

The torque is conducted through elastomer buffers, so the coupling has typically flexible rubber properties.

Thanks to their robust design, RUPEX couplings are also suitable for rough operating conditions.

Benefits

RUPEX couplings can also hold loads when overloaded and are therefore especially suitable for drives for special safety and reliability requirements.

Torque shock loads and changing loads are no problem for robust, compact flexible RUPEX couplings.

The steel variant is also especially suitable for high-speed drives.

RUPEX couplings are fitted by putting together the coupling halves. Fitting with low torsional backlash is simplified by the barrel-shaped geometry of the buffers.

RUPEX couplings require little maintenance. Only the elastomer buffers, as wear parts, need be replaced and the coupled machines need not be moved to do so.

RUPEX couplings are suitable for reversing operation and horizontal and vertical fitting or fitting at any required angle.

Application

RUPEX couplings are available as a catalog standard in 26 sizes with a rated torque of between 200 Nm and 1690000 Nm.

The coupling is suitable for use at ambient temperatures of between -30 °C and +80 °C. By using alternative elastomer buffers, the permissible ambient temperature range can be extended to between -50 °C and +100 °C.

Frequently, the coupling is used to connect the gear shaft to the driven machine. In the case of drives without gear units, the coupling is particularly suitable for operation in rough conditions or heavy-duty drives with electric motor drive. Ventilator drives with high ventilator mass and drives in the cement industry are typical applications.

Examples of particularly safety-relevant areas of application are cable railway drives, lifting gear for crane drives or escalator drives.

GENERAL

Design and configurations

A RUPEX coupling comprises two hub sections which are mounted on the machine shafts. The hub parts are connected positively by steel pins and elastomer buffers. The coupling can be fitted with add-on parts such as brake disks or brake drums.

Up to size 360, the pins and buffers are fitted on one side. From size 400 up, the pins and buffers are fitted in the hubs on alternate sides.

Materials

- Hubs:
Types RWN and RWB made of grey cast iron EN-GJL-250
Types RWS and RBS made of steel
- Flange:
Types RFN, RFS made of steel
- Pins:
Material steel 42CrMo4, surface fine-machined

- Brake disks:
Type RWB made of EN-GJS-400 spheroidal graphite cast iron
Type RBS made of steel
- Brake drums:
Type RWB made of EN-GJL-250 grey cast iron
Type RBS made of steel

Buffer material

Material/description	Hardness	Marking	Ambient temperature
NBR standard type	80 ShoreA	Buffer black	-30 °C ... +80 °C
NBR electrically insulating	80 ShoreA	Buffer green	-30 °C ... +80 °C
NBR soft	65 ShoreA	Buffer black with green dot	-30 °C ... +80 °C
NBR hard	90 ShoreA	Buffer black with magenta dot	-30 °C ... +80 °C
NR for low temperature	80 ShoreA	Buffer black with white dot	-50 °C ... +50 °C
HNBR high temperature	80 ShoreA	Buffer black with red dot	-10 °C ... +100 °C

RUPEX pin and bush coupling types

Type	Description
RWN	Coupling made of grey cast iron
RWS	Coupling made of steel
RWB	Coupling made of grey cast iron with brake drum or brake disk
RBS	Coupling made of steel with brake drum or brake disk
RFN	Coupling made of grey cast iron in flange-shaft variant
RFS	Coupling made of steel in flange-shaft variant

Further application-related coupling types are available. Dimension sheets for and information on these are available on request.

RUPEX pin and bush coupling types on request

Type	Description
All	Coupling with axial backlash limitation
	Coupling with pretensioned buffers
RKS	Coupling with lengthened pins and spacer sleeves
	Coupling for engaging/disengaging during standstill
RWNH, RWSH	Coupling with extension piece
RBM	Coupling with lengthened pins for sliding rotor motors
RAK	Coupling combination RUPEX with ARPEX all-steel membrane coupling

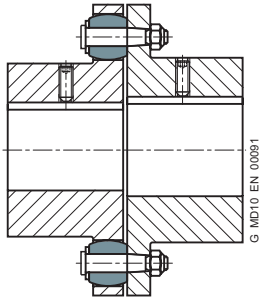

up to size 360

Types RWN/RWS – One-sided arrangement of pins and buffers

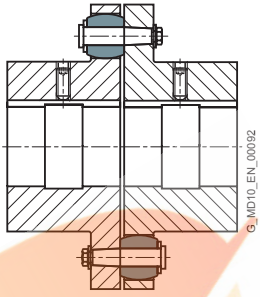

from size 400

Types RWN/RWS – Alternate-sided arrangement of pins and buffers

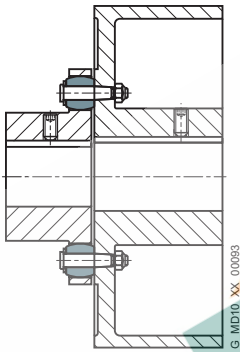

Types RWB/RBS with brake drum

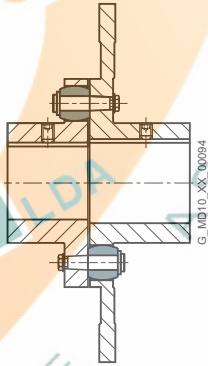

Types RWB/RBS with brake disk

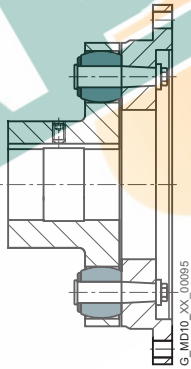

Types RFN, RFS

GENERAL

Function

The motor torque is transmitted to the hub on the drive side via the shaft-hub connection, which is mostly designed as a keyway connection. With the aid of elastomer buffers mounted on steel pins, the torque is conducted to the hub on the output side. The hub on the output side

further transmits the torque to the driven machine or a gear unit located in between. Because of the primarily compression-loaded buffers, the coupling has a progressive torsional stiffness.

Technical specifications

Size	Rated torque for buffer type		Maximum torque for buffer type		Torsional stiffness at 50 % capacity utilization for buffer type			Assembly Gap dimension ΔS mm	Permitted shaft misalignment at n = 1500 rpm ¹⁾	
	65 ShoreA	80/90 ShoreA	65 ShoreA	80/90 ShoreA	65 ShoreA	80 ShoreA	90 ShoreA		Radial ΔK _r mm	Angle ΔK _w Degree
	T _{KN} Nm	T _{KN} ²⁾ Nm	T _{Kmax} Nm	T _{Kmax} Nm	C _{Tdyn} 50 % kNm/rad	C _{Tdyn} 50 % kNm/rad	C _{Tdyn} 50 % kNm/rad			
105	120	200	360	600	5	13	21	1	0.21	0.12
125	210	350	630	1050	9	25	37	1	0.23	0.11
144	300	500	900	1500	15	43	64	1	0.25	0.1
162	450	750	1350	2250	20	55	83	1.5	0.27	0.1
178	570	950	1710	2850	31	85	130	1.5	0.29	0.09
198	780	1300	2340	3900	43	123	187	1.5	0.3	0.09
228	1300	2200	3900	6600	65	184	270	1.5	0.34	0.09
252	1650	2750	4950	8250	92	256	380	1.5	0.36	0.08
285	2600	4300	7800	12900	141	390	560	1.5	0.4	0.08
320	3300	5500	9900	16500	195	540	790	1.5	0.43	0.08
360	4700	7800	14100	23400	276	610	940	1.5	0.48	0.08
400	7500	12500	22500	37500	410	1130	1710	1.5	0.52	0.07
450	11000	18500	33000	55500	570	1600	2380	1.5	0.57	0.07
500	15000	25000	45000	75000	860	2350	3600	1.5	0.62	0.07
560	23500	39000	70500	117000	1130	3070	4700	2	0.68	0.07
630	31000	52000	93000	156000	1640	4600	7400	2	0.75	0.07
710	50000	84000	150000	252000	2560	7200	10900	2	0.84	0.07
800	66000	110000	198000	330000	3900	10700	16700	2	0.93	0.07
900	90000	150000	270000	450000	5200	14300	22500	2.5	1.03	0.07
1000	115000	195000	345000	585000	7700	21300	33000	2.5	1.14	0.07
1120	160000	270000	480000	810000	9800	27300	44000	2.5	1.26	0.06
1250	205000	345000	615000	1035000	14000	39000	62000	2.5	1.39	0.06
1400	320000	530000	960000	1590000	22800	62000	97000	3	1.55	0.06
1600	450000	750000	1350000	2250000	37000	103000	160000	3	1.76	0.06
1800	585000	975000	1755000	2925000	48000	133000	208000	4	1.96	0.06
2000	780000	1300000	2340000	3900000	73000	201000	314000	4	2.17	0.06

For coupling fatigue torque:

$$T_{KW} = 0,20 \cdot T_{KN}$$

Note

For fitting, the maximum gap dimension of S max. = S + ΔS and the minimum gap dimension of S min. = S - ΔS are permitted.

¹⁾ The maximum speed for the respective type must be noted. For additional information on the allowable shaft misalignment, please refer to the operating instructions.

²⁾ Higher rated torque permitted for steel hubs with buffer version 90 Shore A. See information in the type tables for details.

Torsional stiffness and damping

The values stated in the above table apply to a capacity utilization of 50 %, an excitation amplitude of 10 % T_{KN} with the frequency 10 Hz and an ambient temperature of 20 °C. The dynamic torsional stiffness is load-dependent and increases in proportion to capacity utilization. The following table shows the correction factors for different rated loads.

$$C_{Tdyn} = C_{Tdyn\ 50\ \%} \cdot FKC$$

	Load T_N / T_{KN}							
	20%	40%	50%	60%	70%	80%	90%	100%
Correction factor FKC 65/80/90 ShoreA	0.51	0.83	1	1.18	1.38	1.58	1.8	2.03

The damping coefficient is $\Psi = 1.4$

Torsional stiffness and damping is further dependent on the ambient temperature and the frequency and amplitude of the torsional vibration excitation. More precise torsional stiffness and damping parameters on request.

With flexible couplings the manufacturing process of the rubber elements and their aging primarily influence the stiffness value C_{Tdyn} . For this reason calculation must be made with a tolerance for the dynamic stiffness of $\pm 20\ %$. The specified damping coefficient Ψ is a minimum value with the result that the damping performance of the coupling corresponds at least to the specified value.

Permitted shaft misalignment

The permitted shaft misalignment depends on the operating speed. As the speed increases, lower shaft misalignment values are permitted. The correction factors for different speeds are specified in the following table. The maximum speed for the respective coupling size and type must be noted!

$$\Delta K_{perm} = \Delta K_{1500} \cdot FKV$$

	Speed in rpm			
	500	1000	1500	3000
Correction factor FKV	1.7	1.2	1.0	0.7

For fitting, the maximum gap dimension of $S_{max.} = S + \Delta S$ and the minimum gap dimension of $S_{min.} = S - \Delta S$ are permitted.

Shaft misalignments ΔK_r and ΔK_w may occur simultaneously.

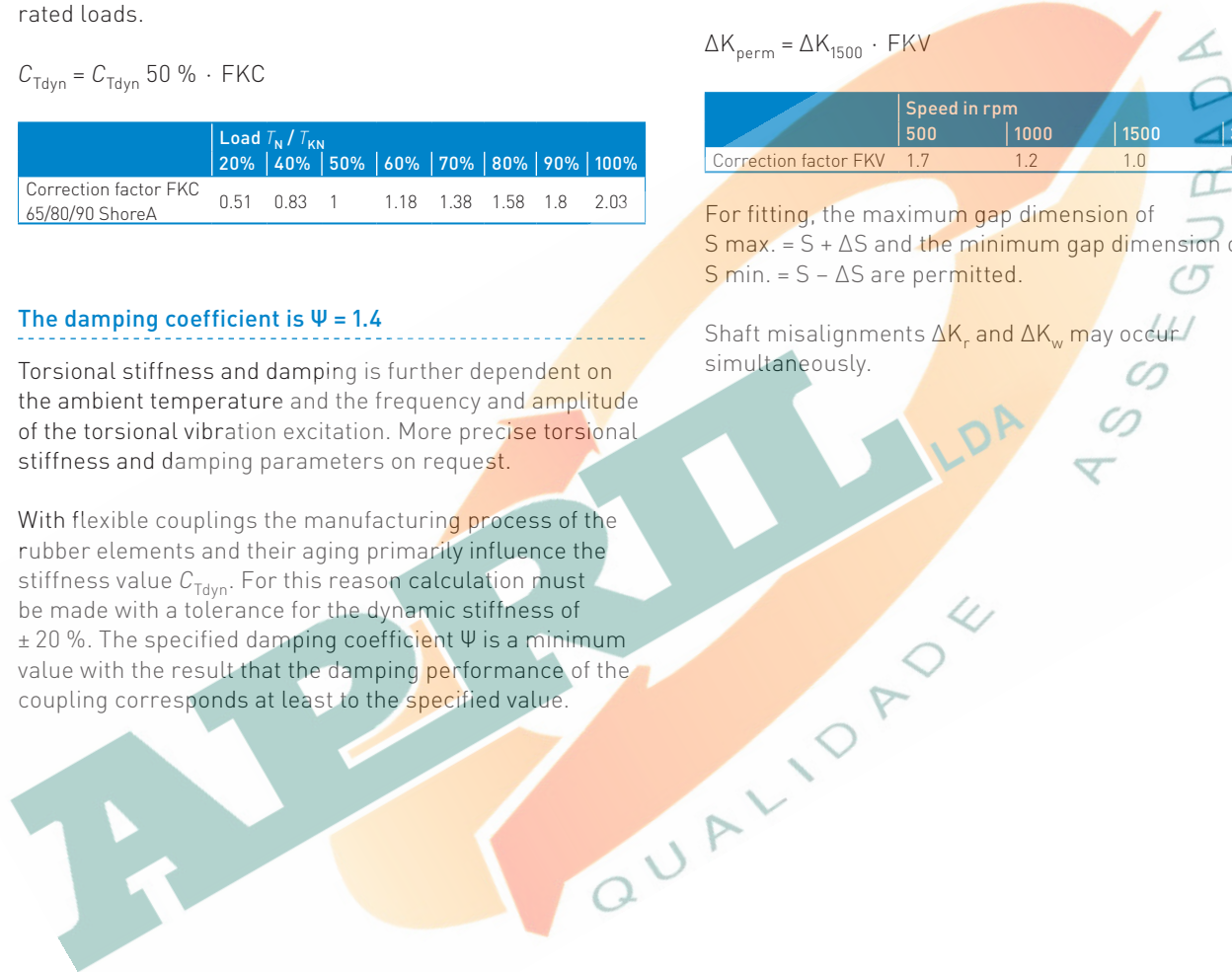

TYPE RWN

Hub material grey cast iron

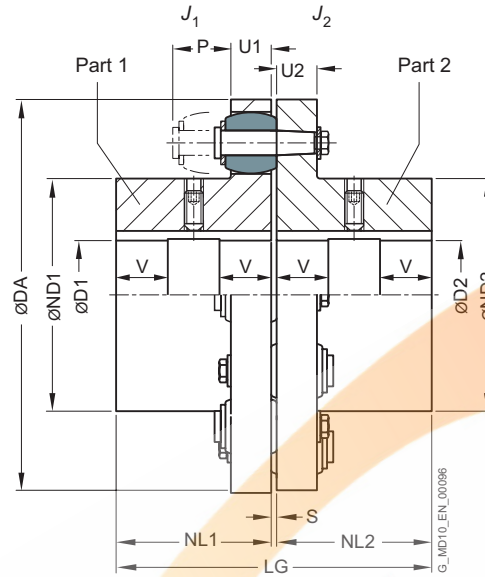

Size	Rated torque buffer 80 ShoreA T_{KN}	Speed n_{Kmax}	Dimensions in mm														Mass moment of inertia		Article no. ¹⁾	Weight m
			Bore with keyway DIN 6885-1				DA	ND1	ND2	NL1/ NL2	S	U1	U2	P	LG	J_1	J_2			
			D1	D2	min.	max.														
105 ²⁾	200	7000	-	35	-	42	105	53	59	45	3	13	12	30	93	0.001	0.001	2LC0130-1AA	1.8	
125 ²⁾	350	6000	-	42	-	48	125	65	68	50	3	16	15	35	103	0.003	0.003	2LC0130-2AA	3.2	
144	500	5250	-	48	-	60	144	76	84	55	3	16	15	35	113	0.004	0.006	2LC0130-3AA	4.2	
162	750	4650	-	55	-	65	162	85	92	60	3.5	20	18	40	123.5	0.007	0.013	2LC0130-4AA	6.3	
178	950	4200	-	70	-	75	178	102	108	70	3.5	20	18	40	143.5	0.013	0.022	2LC0130-5AA	8.9	
198	1300	3750	-	80	-	90	198	120	128	80	3.5	20	18	40	163.5	0.021	0.029	2LC0130-6AA	11.5	
228	2200	3300	-	90	-	95	228	129	140	90	3.5	26	24	50	183.5	0.036	0.070	2LC0130-7AA	17.7	
252	2750	3000	-	100	-	110	252	150	160	100	3.5	26	24	50	203.5	0.068	0.12	2LC0130-8AA	24	
285	4300	2650	48	110	48	120	285	164	175	110	4.5	32	30	60	224.5	0.13	0.22	2LC0131-0AA	36	
320	5500	2350	55	120	55	130	320	180	192	125	4.5	32	30	60	254.5	0.22	0.29	2LC0131-1AA	50	
360	7800	2100	65	130	65	140	360	200	210	140	4.5	42	42	75	284.5	0.40	0.69	2LC0131-2AA	74	
400	12500	2050	75	150	75	150	400	230	230	160	4.5	42	42	75	324.5	0.86	0.86	2LC0131-3AA	100	
450	18500	1800	85	170	85	170	450	260	260	180	5.5	52	52	90	365.5	1.7	1.7	2LC0131-4AA	149	
500	25000	1600	95	190	95	190	500	290	290	200	5.5	52	52	90	405.5	2.8	2.8	2LC0131-5AA	192	
560	39000	1500	100	140	100	140	560	300	300	220	6	68	68	120	446	4.6	4.6	2LC0131-6AA	280	
			140	180	140	180		320	320	5	5	290								
			180	200	180	200		320	320	5.1	5.1	295								
630	52000	1280	100	140	100	140	630	250	250	240	6	68	68	120	486	7.2	7.2	2LC0131-7AA	345	
			140	180	140	180		300	300							7.7	7.7		370	
			180	220	180	220		355	355							8.4	8.4		400	
710	84000	1150	110	160	110	160	710	290	290	260	7	80	80	140	527	13	13	2LC0131-8AA	510	
			160	200	160	200		330	330							14	14		515	
			200	240	200	240		385	385							15	15		540	

Configurable variants ¹⁾

- ØD1 Without finished bore
With finished bore
- ØD2 Without finished bore
With finished bore

¹⁾ To identify complete item numbers specifying the available finish boring options and – if necessary – further order options, please use our configurators on flender.com.

²⁾ Hub material spheroidal graphite iron EN-GJS 400.

➤ For online configuration on flender.com, click on the item no.

Size	Rated torque buffer 80 ShoreA T_{KN} Nm	Speed n_{Kmax} rpm	Dimensions in mm												Mass moment of inertia		Article no. ¹⁾	Weight m kg	
			Bore with keyway DIN 6885-1				DA	ND1	ND2	NL1/NL2	S	U1	U2	P	LG	J_1 kgm ²			J_2 kgm ²
			min.	max.	min.	max.													
800	110000	1000	125	180	125	180	800	320	320	290	7	80	80	140	587	22	22	2LC0132-0AA	670
			180	220	180	220		360	360							23	23		690
			220	260	220	260		420	420							24.5	24.5		730
900	150000	900	140	220	140	220	900	360	360	320	7.5	90	90	160	647.5	39	39	2LC0132-1AA	940
			220	260	220	260		425	425							41	41		960
			260	290	260	290		465	465							43	43		1030
1000	195000	810	150	240	150	240	1000	395	395	350	7.5	90	90	160	707.5	60	60	2LC0132-2AA	1200
			240	280	240	280		460	460							63	63		1250
			280	320	280	320		515	515							68	68		1310
1120	270000	700	160	200	160	200	1120	360	360	380	8.5	100	100	180	768.5	98	98	2LC0132-3AA	1470
			200	250	200	250		410	410							100	100		1510
			250	300	250	300		495	495							105	105		1600
1250	345000	650	300	350	300	350	1250	560	560	420	8.5	100	100	180	848.5	110	110	2LC0132-4AA	1690
			180	230	180	230		410	410							150	150		1850
			230	280	230	280		460	460							155	155		1900
1400	530000	570	280	330	280	330	1400	540	540	480	9	120	120	210	969	165	165	2LC0132-5AA	2025
			330	380	330	380		610	610							175	175		2210
			200	260	200	260		465	465							290	290		2820
1600	750000	500	260	320	260	320	1600	525	525	540	9	120	120	210	1089	300	300	2LC0132-6AA	2900
			320	380	320	380		620	620							310	310		3180
			380	440	380	440		700	700							330	330		3260
1800	975000	450	260	320	260	320	1800	565	565	600	12	140	140	240	1212	490	490	2LC0132-7AA	3780
			320	380	320	380		625	625							500	500		3870
			380	440	380	440		720	720							530	530		4150
2000	1300000	400	440	480	440	480	2000	770	770	660	12	140	140	240	1332	550	550	2LC0132-8AA	4290
			320	380	320	380		660	660							850	850		5550
			380	440	380	440		720	720							930	930		5630
2000	1300000	400	440	500	440	500	2000	820	820	660	12	140	140	240	1332	980	980	2LC0132-8AA	6000
			500	560	500	560		870	870							1050	1050		6250
			560	600	560	600		920	920							1350	1350		6800
							960	960							1400	1400		7000	
															1500	1500		7350	
															1550	1550		7620	

Configurable variants¹⁾

- ØD1 Without finished bore
With finished bore
- ØD2 Without finished bore
With finished bore

Notes

- From size 560 bores D1 and D2 are each provided with a recess of D = +1 mm halfway along the hub. $V \approx 1/3 NL$
- The hub diameter of the component part is assigned according to the diameter of the finished bore. Where bore diameters overlap, the component with the smaller hub diameter is always selected.
- Weight and mass moments of inertia apply to maximum bore diameters.
- The article numbers apply to standard buffers of NBR material in the 80 ShoreA variant; the article number for alternative buffer types is available on request.

Ordering example

- RUPEX RWN coupling, size 710
- Part 1: Hub left with bore 180H7 mm, with keyway to DIN 6885-1 and set screw
- Part 2: Hub right with bore 200H7 mm, with keyway to DIN 6885-1 and set screw.

Article no.: 2LC0131-8AA99-0AA0 L2B+M2D

¹⁾ To identify complete item numbers specifying the available finish boring options and – if necessary – further order options, please use our configurators on flender.com.

➤ For online configuration on flender.com, click on the item no.

TYPE RWS

Hub material steel

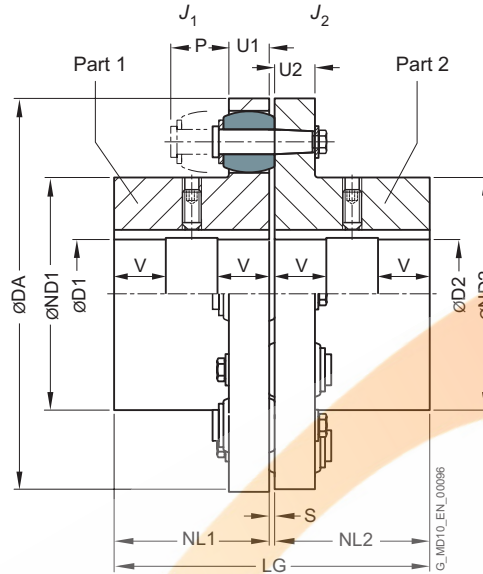

Size	Rated torque		Speed n_{Kmax} rpm	Dimensions in mm													Mass moment of inertia		Article no. ²⁾	Weight m kg
	buffer 90 ShoreA $T_{KN}^{1)}$ Nm	buffer 80 ShoreA T_{KN} Nm		Bore with keyway DIN 6885-1 D1				DA	ND1	ND2	NL1/ NL2	S	U1	U2	P	LG	J_1 kgm ²	J_2 kgm ²		
				min.	max.	min.	max.													
105	260	200	10000	-	38	-	42	105	53	59	45	3	13	12	30	93	0.001	0.001	2LC0130-1AB	1.7
125	450	350	9000	-	48	-	50	125	65	68	50	3	16	15	35	103	0.003	0.003	2LC0130-2AB	3.0
144	650	500	7800	-	55	-	60	144	76	84	55	3	16	15	35	113	0.004	0.006	2LC0130-3AB	4.3
162	950	750	6900	-	60	-	65	162	85	92	60	3.5	20	18	40	123.5	0.007	0.013	2LC0130-4AB	6.5
178	1200	950	6300	-	75	-	80	178	102	108	70	3.5	20	18	40	143.5	0.014	0.021	2LC0130-5AB	9.1
198	1700	1300	5600	-	90	-	95	198	120	128	80	3.5	20	18	40	163.5	0.020	0.028	2LC0130-6AB	11.2
228	2850	2200	4900	-	95	-	100	228	129	140	90	3.5	26	24	50	183.5	0.036	0.070	2LC0130-7AB	17.5
252	3550	2750	4400	-	110	-	120	252	150	160	100	3.5	26	24	50	203.5	0.066	0.115	2LC0130-8AB	23.6
285	5600	4300	3900	-	120	-	130	285	164	175	110	4.5	32	30	60	224.5	0.12	0.21	2LC0131-0AB	36
320	7150	5500	3500	55	130	55	140	320	180	192	125	4.5	32	30	60	254.5	0.23	0.29	2LC0131-1AB	50
360	10000	7800	3100	65	145	65	150	360	200	210	140	4.5	42	42	75	284.5	0.40	0.69	2LC0131-2AB	73
400	16000	12500	2800	75	170	75	170	400	230	230	160	4.5	42	42	75	324.5	0.83	0.83	2LC0131-3AB	97
450	24000	18500	2500	85	190	85	190	450	260	260	180	5.5	52	52	90	365.5	1.6	1.6	2LC0131-4AB	147
500	32500	25000	2200	95	215	95	215	500	290	290	200	5.5	52	52	90	405.5	2.7	2.7	2LC0131-5AB	192
560	50500	39000	2000	100	165	100	165		250	250						4.8	4.8		274	
				165	200	165	200	560	300	300	220	6	68	68	120	446	5.2	5.2	2LC0131-6AB	292
				200	240	200	240		320	320							5.2	5.2		268
630	67500	52000	1800	100	165	100	165		250	250					7.6	7.6		352		
				165	200	165	200	630	300	300	240	6	68	68	120	486	7.9	7.9	2LC0131-7AB	370
				200	265	200	265		355	355							8.4	8.4		356
710	109000	84000	1600	110	190	110	190		290	290					14.4	14.4		507		
				190	220	190	220	710	330	330	260	7	80	80	140	527	14.6	14.6	2LC0131-8AB	530
				220	280	220	280		385	385							15.5	15.5		509

Configurable variants ²⁾

- ØD1 Without finished bore
With finished bore
- ØD2 Without finished bore
With finished bore

¹⁾ T_{Kmax} is given in the specifications on Page 8/6.
 T_{KW} is determined from the specifications given on Page 8/6.

²⁾ To identify complete item numbers specifying the available finish boring options and – if necessary – further order options, please use our configurators on flender.com.

↗ For online configuration on flender.com, click on the item no.

Size	Rated torque		Speed n_{Kmax} rpm	Dimensions in mm											Mass moment of inertia		Article no. ²⁾	Weight m kg		
	buffer 90 ShoreA $T_{KN}^{1)}$ Nm	buffer 80 ShoreA T_{KN} Nm		Bore with keyway DIN 6885-1				DA	ND1	ND2	NL1/ NL2	S	U1	U2	P	LG			J_1 kgm ²	J_2 kgm ²
	D1			D2		min.	max.													
800	143000	110000	1400	125	210	125	210	800	320	320	290	7	80	80	140	587	23.1	23.1	2LC0132-0AB	683
				210	240	210	240		360	360							23.3	23.3		715
				240	310	240	310		420	420							25.0	25.0		699
900	195000	150000	1250	140	210	140	210	900	320	320	320	7.5	90	90	160	647.5	40	40	2LC0132-1AB	907
				210	240	210	240		360	360							41	41		933
				240	280	240	280		425	425							44	44		1000
				280	340	280	340		465	465							44	44		948
1000	250000	195000	1100	150	230	150	230	1000	355	355	350	7.5	90	90	160	707.5	63	63	2LC0132-2AB	1170
				230	260	230	260		395	395							64	64		1208
				260	300	260	300		460	460							68	68		1290
				300	380	300	380		515	515							68	68		1220
1120	350000	270000	1000	160	240	160	240	1120	360	360	380	8.5	100	100	180	768.5	105	105	2LC0132-3AB	1560
				240	270	240	270		410	410							106	106		1660
				270	330	270	330		495	495							109	109		1730
				330	410	330	410		560	560							116	116		1720
1250	450000	345000	900	180	270	180	270	1250	410	410	420	8.5	100	100	180	848.5	168	168	2LC0132-4AB	2000
				270	300	270	300		460	460							172	172		2150
				300	360	300	360		540	540							179	179		2200
				360	440	360	440		610	610							185	185		2250
1400	690000	530000	800	200	310	200	310	1400	465	465	480	9	120	120	210	969	316	316	2LC0132-5AB	3020
				310	350	310	350		525	525							322	322		3120
				350	410	350	410		620	620							337	337		3350
				410	510	410	510		700	700							349	349		3280
1600	975000	750000	700	260	370	260	370	1600	565	565	540	9	120	120	210	1089	540	540	2LC0132-6AB	3890
				370	410	370	410		625	625							554	554		4270
				410	480	410	480		720	720							587	587		4300
				480	560	480	560		770	770							598	598		4270
1800	1260000	975000	600	320	440	320	440	1800	660	660	600	12	140	140	240	1212	1043	1043	2LC0132-7AB	6230
				440	480	440	480		720	720							1072	1072		6460
				480	540	480	540		820	820							1122	1122		6770
				540	650	540	650		870	870							1113	1113		6390
2000	1690000	1300000	550	380	500	380	500	2000	760	760	660	12	140	240	1332	1628	1628	1628	2LC0132-8AB	8140
				500	540	500	540		820	820							1664	1664		8430
				540	610	540	610		920	920							1735	1735		8860
				610	710	610	710		960	960							1749	1749		8280

Configurable variants ²⁾

- ØD1 Without finished bore
With finished bore
- ØD2 Without finished bore
With finished bore

Notes

- From size 560 bores D1 and D2 are each provided with a recess of D = +1 mm halfway along the hub. V ≈ 1/3 NL
- The hub diameter of the component part is assigned according to the diameter of the finished bore. Where bore diameters overlap, the component with the smaller hub diameter is always selected.
- Weight and mass moments of inertia apply to maximum bore diameters.
- The article numbers apply to standard buffers of NBR material in the 80 ShoreA variant; the article number for alternative buffer types is available on request.

Ordering example

- RUPEX RWS coupling, size 710
- Part 1: Hub left with bore 180H7 mm, with keyway to DIN 6885-1 and set screw
- Part 2: Hub right with bore 200H7 mm, with keyway to DIN 6885-1 and set screw.
- Coupling micro-balanced G 6.3 at 1500 rpm in accordance with half parallel key standard

Article no.: 2LC0131-8AB99-0AA0-Z L2B+M2D+W02+Y95
Plain text to Y95: G=6.3;n=1500rpm

¹⁾ T_{Kmax} is given in the specifications on Page 8/6.
 T_{KW} is determined from the specifications given on Page 8/6.

²⁾ To identify complete item numbers specifying the available finish boring options and – if necessary – further order options, please use our configurators on flender.com.

↗ For online configuration on flender.com, click on the item no.

TYPE RFN

Hub material grey cast iron

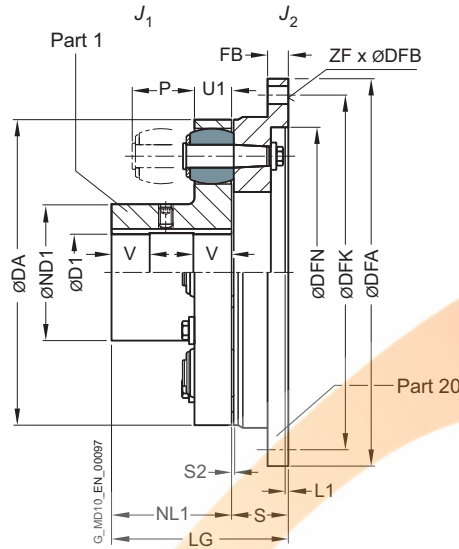

Size	Rated torque buffer 80 ShoreA T_{KN} Nm	Speed n_{Kmax} rpm	Dimensions in mm													Mass moment of inertia		Article no. ¹⁾	Weight m kg	
			Bore with keyway DIN 6885-1 D1 min. max.		DA	ND1	NL1	S	LG	Flange connection						J_1 kgm ²	J_2 kgm ²			
										DFA h8	FB	DFN H7	L1	DFK	ZF	DFB				
105	200	7000	-	35	105	53	45	26	71	158	10			142	6	9	0.001	0.005	2LC0130-1AJ	2.2
125	350	6000	-	42	125	65	50	31	81	180	13			160	6	11	0.003	0.012	2LC0130-2AJ	4.1
144	500	5250	-	48	144	76	55	31	86	200	13			180	7	11	0.004	0.018	2LC0130-3AJ	4.9
162	750	4650	-	55	162	85	60	37.5	97.5	220	13			200	8	11	0.007	0.032	2LC0130-4AJ	7.1
178	950	4200	-	70	178	102	70	37.5	107.5	248	16			224	8	14	0.013	0.055	2LC0130-5AJ	9
198	1300	3750	-	80	198	120	80	37.5	117.5	274	16			250	8	14	0.021	0.08	2LC0130-6AJ	12
228	2200	3300	-	90	228	129	90	45.5	135.5	314	20			282	8	18	0.036	0.18	2LC0130-7AJ	19
252	2750	3000	-	100	252	150	100	45.5	145.5	344	20			312	8	18	0.068	0.26	2LC0130-8AJ	24
285	4300	2650	48	110	285	164	110	55.5	165.5	380	22			348	9	18	0.13	0.46	2LC0131-0AJ	37
320	5500	2350	55	120	320	180	125	55.5	175.5	430	25			390	9	22	0.22	0.76	2LC0131-1AJ	48
360	7800	2100	65	130	360	200	140	70.5	210.5	480	25			440	10	22	0.40	1.4	2LC0131-2AJ	74
400	12500	2050	75	150	400	230	160	74.5	234.5	520	50	380	4	480	10	22	0.86	1.8	2LC0131-3AJ	122
450	18500	1800	85	170	450	260	180	85.5	265.5	575	45	428	6	528	12	26	1.7	3.2	2LC0131-4AJ	166
500	25000	1600	95	190	500	290	200	85.5	285.5	620	45	475	6	570	12	26	2.8	4.3	2LC0131-5AJ	200

Configurable variants ¹⁾

- ØD1 Without finished bore
With finished bore

¹⁾ To identify complete item numbers specifying the available finish boring options and – if necessary – further order options, please use our configurators on flender.com.

↗ For online configuration on flender.com, click on the item no.

Size	Rated torque buffer 80 ShoreA	Speed	Dimensions in mm													Mass moment of inertia		Article no. ¹⁾	Weight		
			Bore with keyway DIN 6885-1		DA	ND1	NL1	S	LG	Flange connection						J ₁ kgm ²	J ₂ kgm ²			m kg	
T _{KN} Nm	n _{Kmax} rpm	D1 min.	D1 max.	DFN H7						L1	DFK	ZF	DFB	h8	FB			DFN H7	L1		DFK
560	39000	1500	100	140	560	250	300	220	106	326	700	65	532	8	650	16	26	4.6	8.2	2LC0131-6AJ	330
			140	180		320												5.1			330
			180	200		320												5.1			340
630	52000	1280	100	140	630	250	300	240	106	346	785	60	602	8	725	16	33	7.2	13.8	2LC0131-7AJ	390
			140	180		355												7.7			400
			180	220		355												8.4			420
710	84000	1150	110	160	710	290	330	260	127	387	875	80	675	10	815	18	33	13	26	2LC0131-8AJ	550
			160	200		385												14			550
			200	240		385												15			570
800	110000	1000	125	180	800	320	360	290	127	417	1000	70	765	10	930	16	39	22	45	2LC0131-9AJ	680
			180	220		420												23			690
			220	260		420												24.5			710

Configurable variants ¹⁾

- ØD1 Without finished bore
With finished bore

Notes

- For dimensions U1, P and S2, see type RWN on **Page 8/8**
- From size 560 bore D1 is provided with a recess of D = +1 mm half way along the hub.
V ≈ 1/3 NL
- Weight and mass moments of inertia apply to maximum bore diameters.
- The article numbers apply to standard buffers of NBR material in the 80 ShoreA variant; the article number for alternative buffer types is available on request.

Ordering example

- RUPEX RFN coupling, size 560
- Part 1: Hub left with bore 180H7 mm, with keyway to DIN 6885-1 and set screw

Article no.: 2LC0131-6AJ91-0AA0 L2B

¹⁾ To identify complete item numbers specifying the available finish boring options and – if necessary – further order options, please use our configurators on flender.com.

↗ For online configuration on flender.com, click on the item no.

TYPE RFS

Hub material steel

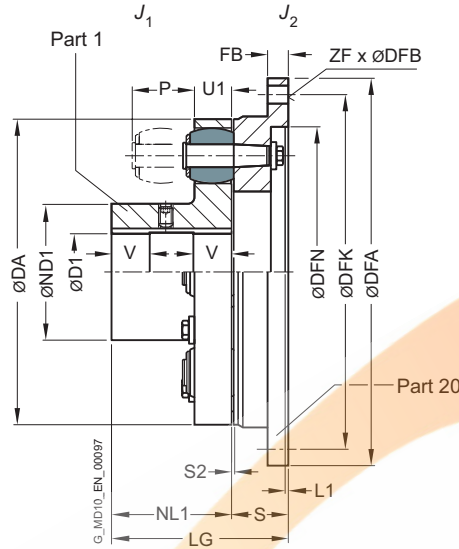

Size	Rated torque		Speed	Dimensions in mm											Mass moment of inertia			Article no. ²⁾	Weight		
	buffer 90 ShoreA	buffer 80 ShoreA		Bore with keyway DIN 6885-1					Flange connection						J ₁	J ₂	m				
	T _{KN} ¹⁾ Nm	T _{KN} Nm	n _{Kmax} rpm	D1	DA	ND1	NL1	S	LG	DFA	FB	DFN	L1	DFK	ZF	DFB	kgm ²	kgm ²	kg		
105	260	200	10000	-	38	105	53	45	26	71	158	10		142	6	9	0.001	0.005	2LC0130-1AK	2.2	
125	450	350	9000	-	48	125	65	50	31	81	180	13		160	6	11	0.003	0.012	2LC0130-2AK	4.0	
144	650	500	7800	-	55	144	76	55	31	86	200	13		180	7	11	0.004	0.018	2LC0130-3AK	4.8	
162	950	750	6900	-	60	162	85	60	37.5	97.5	220	13		200	8	11	0.007	0.032	2LC0130-4AK	7.1	
178	1200	950	6300	-	75	178	102	70	37.5	107.5	248	16		224	8	14	0.014	0.055	2LC0130-5AK	10	
198	1700	1300	5600	-	90	198	120	80	37.5	117.5	274	16		250	8	14	0.020	0.08	2LC0130-6AK	12	
228	2850	2200	4900	-	95	228	129	90	45.5	135.5	314	20		282	8	18	0.036	0.18	2LC0130-7AK	19	
252	3550	2750	4400	-	110	252	150	100	45.5	145.5	344	20		312	8	18	0.066	0.26	2LC0130-8AK	24	
285	5600	4300	3900	48	120	285	164	110	55.5	165.5	380	22		348	9	18	0.12	0.46	2LC0131-0AK	36	
320	7150	5500	3500	55	130	320	180	125	55.5	175.5	430	25		390	9	22	0.23	0.76	2LC0131-1AK	49	
360	10000	7800	3100	65	145	360	200	140	70.5	210.5	480	25		440	10	22	0.40	1.4	2LC0131-2AK	74	
400	16000	12500	2800	75	170	400	230	160	74.5	234.5	520	50	380	4	480	10	22	0.83	1.8	2LC0131-3AK	119
450	24000	18500	2500	85	190	450	260	180	85.5	265.5	575	45	428	6	528	12	26	1.6	3.2	2LC0131-4AK	167
500	32500	25000	2200	95	215	500	290	200	85.5	285.5	620	45	475	6	570	12	26	2.7	4.3	2LC0131-5AK	198

Configurable variants ²⁾

- ØD1 Without finished bore
With finished bore

¹⁾ T_{Kmax} is given in the specifications on Page 8/6.

T_{KW} is determined from the specifications given on Page 8/6.

²⁾ To identify complete item numbers specifying the available finish boring options and – if necessary – further order options, please use our configurators on flender.com.

↗ For online configuration on flender.com, click on the item no.

Size	Rated torque		Speed n_{Kmax} rpm	Dimensions in mm														Mass moment of inertia		Article no. ²⁾	Weight m kg	
	buffer 90 ShoreA	buffer 80 ShoreA		Bore with keyway DIN 6885-1							Flange connection							J_1 kgm ²	J_2 kgm ²			
	$T_{KN}^{1)}$ Nm	T_{KN} Nm		D1 min.	D1 max.	DA	ND1	NL1	S	LG	DFA h8	FB	DFN H7	L1	DFK	ZF	DFB					
560	50500	39000	2000	100	165	560	250	300	220	106	326	700	65	532	8	650	16	26	4.8	8.2	2LC0131-6AK	330
				165	200		320												5.2			340
				200	240		320												5.2			320
630	67500	52000	1800	100	165	630	250	300	240	106	346	785	60	602	8	725	16	33	7.6	13.8	2LC0131-7AK	390
				165	200		355												7.9			400
				200	265		355												8.4			400
710	109000	84000	1600	110	190	710	290	330	260	127	387	875	80	675	10	815	18	33	14.4	26	2LC0131-8AK	550
				190	220		385												14.6			560
				220	280		385												15.5			555
800	143000	110000	1400	125	210	800	320	360	290	127	417	1000	70	765	10	930	16	39	23.1	45	2LC0131-9AK	690
				210	240		420												23.3			710
				240	310		420												25.0			700

Configurable variants ²⁾

- ØD1 Without finished bore
With finished bore

Notes

- For dimensions U1, P and S2, see type RWS on Page 8/10
- From size 560 bore D1 is provided with a recess of D = +1 mm halfway along the hub.
 $V \approx 1/3 NL$
- Weight and mass moments of inertia apply to maximum bore diameters.
- The article numbers apply to standard buffers of NBR material in the 80 ShoreA variant; the article number for alternative buffer types is available on request.

Ordering example

- RUPEX RFS coupling, size 560
- Part 1: Hub left with bore 180H7 mm, with keyway to DIN 6885-1 and set screw
- Coupling micro-balanced G 6.3 at 1500 rpm in accordance with half parallel key standard

Article no.: 2LC0131-6AK91-0AA0-Z L2B+W02+Y95
Plain text to Y95: G=6.3;n=1500rpm

¹⁾ T_{Kmax} is given in the specifications on Page 8/6.
 T_{KW} is determined from the specifications given on Page 8/6.

²⁾ To identify complete item numbers specifying the available finish boring options and – if necessary – further order options, please use our configurators on flender.com.

↗ For online configuration on flender.com, click on the item no.

TYPE RWB

with brake disk to DIN 15432

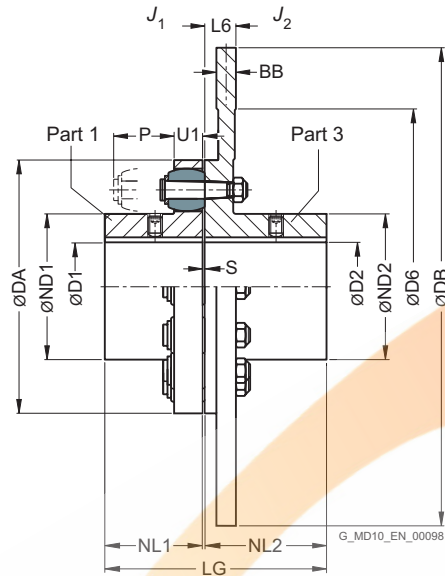

8

Size	Rated torque buffer 80 ShoreA T_{KN} Nm	Dimensions in mm														Article no. ¹⁾				
		Bore with keyway DIN 6885-1				Brake disk														
		D1		D2		DA	ND1	ND2	NL1	NL2	S	U1	P	LG	DB ²⁾	DB	D6	BB ²⁾	L6	
		min.	max.	min.	max.					max.				max.	max.	min.	min.			
144	500	-	48	-	45	144	76	84	55	219	3	16	35	277	500	315	175	30	34	2LC0130-3AE
162	750	-	55	-	50	162	85	92	60	219	3.5	20	40	282.5	560	315	175	30	34	2LC0130-4AE
178	950	-	70	-	60	178	102	108	70	219	3.5	20	40	292.5	560	355	200	30	34	2LC0130-5AE
198	1300	-	80	-	70	198	120	128	80	219	3.5	20	40	302.5	560	355	200	30	34	2LC0130-6AE
228	2200	-	90	-	80	228	129	140	90	219	3.5	26	50	312.5	800	355	250	30	34	2LC0130-7AE
252	2750	-	100	38	100	252	150	160	100	219	3.5	26	50	322.5	800	400	280	30	34	2LC0130-8AE
285	4300	48	110	48	110	285	164	175	110	219	4.5	32	60	333.5	800	400	310	30	34	2LC0131-0AE
320	5500	55	120	55	120	320	180	192	125	219	4.5	32	60	348.5	1000	450	350	30	34	2LC0131-1AE

Configurable variants ¹⁾

- ØD1 Without finished bore
With finished bore
- ØD2 With finished bore

¹⁾ To identify complete item numbers specifying the available finish boring options and – if necessary – further order options, please use our configurators on flender.com.

²⁾ For the available DB·BB brake disk dimensions, please refer to the product configurator on flender.com.

↗ For online configuration on flender.com, click on the item no.

Notes

- Brake disk diameter DB in accordance with customer specification.
- Additional sizes are available on request.
- Further dimensions for part 3 on request.
- Maximum speed in rpm:
 $n_{Kmax} = 1146/DB$ (DB in m)
 Observe maximum speed of type RWN!
- Mass moments of inertia and weights can be sufficiently precisely determined as follows:
 - Mass moments of inertia in kgm^2 :
 $J_1 = J_1$ from type RWN
 $J_2 = J_2$ from type RWN + $710 \times BB \times DB^4$
 (BB and DB in m)
 - Weight in kg:
 $m = m$ from type RWN + $5700 \times BB \times DB^2$
 (BB and DB in m)
- The article numbers apply to standard buffers of NBR material in the 80 ShoreA variant; the article number for alternative buffer types is available on request.

Ordering example

- RUPEX RWB coupling, size 252, brake disk 630 x 30 mm
- Part 1: Bore D1 = 48H7 mm, keyway to DIN 6885-1 and set screw
- Part 3: Bore 42H7 mm, keyway to DIN 6885-1 P9 and set screw.
- Coupling micro-balanced G 6.3 at 1500 rpm in accordance with half parallel key standard
- Mass moment of inertia:
 $J_1 = 0.07 \text{ kgm}^2$
 $J_2 = 0.12 \text{ kgm}^2 + 3.3 \text{ kgm}^2 = 3.42 \text{ kgm}^2$
- Weight:
 $m = 26.3 \text{ kg} + 68 \text{ kg} = 94.3 \text{ kg}$

Article no.: 2LC0130-8AE99-0KA0-Z L1B+M0X+W02+Y95
 Plain text to Y95: G=6.3;n=1500rpm

APRIL LDA
 QUALIDADE ASSEGURADA

TYPE RBS

with brake disk to DIN 15432

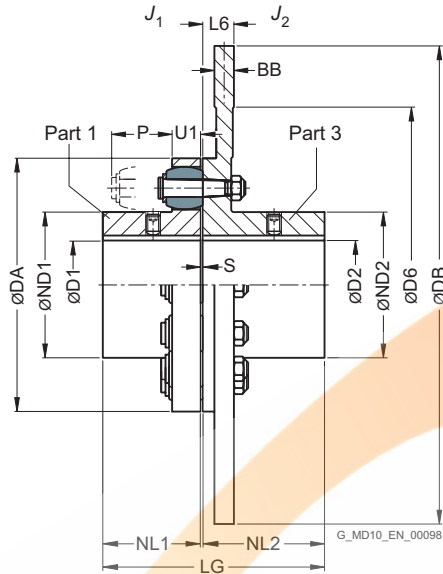

8

Size	Rated torque		Dimensions in mm																	Article no. ²⁾
	buffer 90 ShoreA	buffer 80 ShoreA	Bore with keyway DIN 6885-1				Shaft										Brake disk			
	$T_{KN}^{1)}$ Nm	T_{KN} Nm	D1 min.	D1 max.	D2 min.	D2 max.	DA	ND1	ND2	NL1	NL2 max.	S	U1	P	LG max.	DB ³⁾ min.	D6 min.	BB ³⁾	L6	
144	650	500	-	55	-	45	144	76	84	55	219	3	16	35	277	315	175	30	34	2LC0130-3AH
162	950	750	-	60	-	50	162	85	92	60	219	3.5	20	40	282.5	315	175	30	34	2LC0130-4AH
178	1200	950	-	75	-	60	178	102	108	70	219	3.5	20	40	292.5	355	200	30	34	2LC0130-5AH
198	1700	1300	-	90	-	70	198	120	128	80	219	3.5	20	40	302.5	355	200	30	34	2LC0130-6AH
228	2850	2200	-	95	-	80	228	129	140	90	219	3.5	26	50	312.5	355	250	30	34	2LC0130-7AH
252	3550	2750	-	110	38	100	252	150	160	100	219	3.5	26	50	322.5	400	280	30	34	2LC0130-8AH
285	5600	4300	48	120	48	120	285	164	175	110	219	4.5	32	60	333.5	400	310	30	34	2LC0131-0AH
320	7150	5500	55	130	55	130	320	180	192	125	219	4.5	32	60	348.5	450	350	30	34	2LC0131-1AH
360	10000	7800	65	145	65	140	360	200	210	140	221	4.5	42	75	365.5	560	390	30	36	2LC0131-2AE

Configurable variants ²⁾

- ØD1 Without finished bore
With finished bore
- ØD2 With finished bore

¹⁾ T_{Kmax} is given in the specifications on Page 8/6.

T_{KW} is determined from the specifications given on Page 8/6.

²⁾ To identify complete item numbers specifying the available finish boring options and – if necessary – further order options, please use our configurators on flender.com.

³⁾ For the available DB- BB brake disk dimensions, please refer to the product configurator on flender.com.

↗ For online configuration on flender.com, click on the item no.

Notes

- Brake disk diameter DB in accordance with customer specification.
- Additional sizes are available on request.
- Further dimensions for part 3 on request.
- Maximum speed in rpm:
 $n_{Kmax} = 1528/DB$ (DB in m)
 Observe maximum speed of type RWS!
- Mass moments of inertia and weights can be sufficiently precisely determined as follows:
 - Mass moments of inertia in kgm^2 :
 $J_1 = J_1$ from type RWS
 $J_2 = J_2$ from type RWS + $770 \times BB \times DB^4$
 (BB and DB in m)
 - Weight in kg:
 $m = m$ from type RWS + $6160 \times BB \times DB^2$
 (BB and DB in m)
- The article numbers apply to standard buffers of NBR material in the 80 ShoreA variant; the article number for alternative buffer types is available on request.

Ordering example

- RUPEX RBS coupling, size 252, brake disk 630 x 30 mm
- Part 1: Bore D1 = 48H7 mm, keyway to DIN 6885-1 and set screw
- Part 3: Bore 42H7 mm, keyway to DIN 6885-1 P9 and set screw.
- Coupling micro-balanced G 6.3 at 1500 rpm in accordance with the half parallel key standard.
- Mass moment of inertia:
 $J_1 = 0.07 \text{ kgm}^2$
 $J_2 = 0.12 \text{ kgm}^2 + 3.6 \text{ kgm}^2 = 3.72 \text{ kgm}^2$
- Weight:
 $m = 25.8 \text{ kg} + 73 \text{ kg} = 98.8 \text{ kg}$

Article no.: 2LC0130-8AH99-0KA0-Z L1B+M0X+W02+Y95
 Plain text to Y95: G=6.3;n=1500rpm

APRIL LDA
 QUALIDADE ASSEGURADA

TYPE RBS

with brake disk to DIN 15432

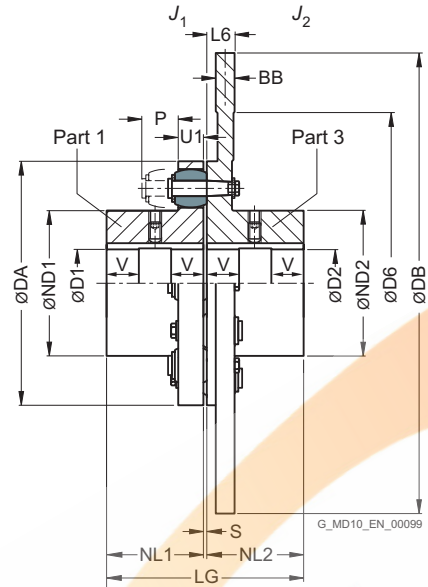

8

Size	Rated torque		Dimensions in mm													Brake disk			Article no. ¹⁾
	buffer 90 ShoreA T_{KN} Nm	buffer 80 ShoreA T_{KN} Nm	Bore with keyway DIN 6885-1				DA	ND1	ND2	NL1	NL2	S	U1	P	LG	D6 ²⁾ min.	BB ²⁾	L6	
			D1 min.	D1 max.	D2 min.	D2 max.													
400	16000	12500	75	170	75	150	400	230	230	160	225	4.5	42	75	389.5	410	30	40	2LC0131-3AH
450	24000	18500	85	190	85	170	450	260	260	180	225	5.5	52	90	410.5	460	30	40	2LC0131-4AH
500	32500	25000	95	215	95	190	500	290	290	200	225	5.5	52	90	430.5	510	30	40	2LC0131-5AH
560	50500	39000	100	165	100	210	560	300	320	220	225	6	68	120	451	570	30	40	2LC0131-6AH
			200	240				320											
630	67500	52000	100	165	100	235	630	300	355	240	240	6	68	120	486	670	30	55	2LC0131-7AH
			200	265				355											

Configurable variants ¹⁾

- ØD1 Without finished bore
With finished bore
- ØD2 With finished bore

¹⁾ To identify complete item numbers specifying the available finish boring options and – if necessary – further order options, please use our configurators on flender.com.

²⁾ For the available DB · BB brake disk dimensions, please refer to the product configurator on flender.com.

↗ For online configuration on flender.com, click on the item no.

Size	Rated torque		Dimensions in mm														Article no. ¹⁾		
	buffer 90 ShoreA T_{KN} Nm	buffer 80 ShoreA T_{KN} Nm	Bore with keyway DIN 6885-1				DA	ND1	ND2	NL1	NL2	S	U1	P	LG	Brake disk			
			D1 min.	D1 max.	D2 min.	D2 max.										D6 ²⁾ min.		BB ²⁾	L6
710	109000	84000	110	190	110	250	710	290	385	260	260	7	80	140	527	760	30	75	2LC0131-8AH
			190	220				330											
			220	250				385											
800	143000	110000	125	210	125	280	800	320	420	290	290	7	80	140	587	840	30	75	2LC0132-0AH
			210	240				360											
			240	280				420											
900	195000	150000	140	210	140	310	900	320	465	320	-	7.5	90	160	647.5	950	30	75	2LC0132-1AH
			210	240				360											
			240	280				425											
1000	250000	195000	150	230	150	340	1000	355	515	350	-	7.5	90	160	707.5	1050	30	75	2LC0132-2AH
			230	260				395											
			260	300				460											
			300	340				515											

Configurable variants¹⁾

- ØD1 Without finished bore
With finished bore
- ØD2 With finished bore

Notes

- From size 560 bores D1 are provided with a recess of D = +1 mm halfway along the hub.
 $V \approx 1/3 NL$
- Brake disk diameter DB in accordance with customer specification.
- Additional sizes are available on request. Further dimensions for part 3 on request.
- Maximum speed in rpm:
 $n_{Kmax} = 1528/DB$ (DB in m)
Observe maximum speed of type RWS!
- Mass moments of inertia and weights can be sufficiently precisely determined as follows:
 - Mass moments of inertia in kgm^2 :
 $J_1 = J_1$ from type RWS
 $J_2 = J_2$ from type RWS + $770 \times BB \times DB^4$ (BB and DB in m)
 - Weight in kg:
 $m = m$ from type RWS + $6160 \times BB \times DB^2$ (BB and DB in m)
- The article numbers apply to standard buffers of NBR material in the 80 ShoreA variant; the article number for alternative buffer types is available on request.

Ordering example

- RUPEX RBS coupling, size 450, brake disk 900 x 30 mm
- Part 1: Bore D1 = 130H7 mm, keyway to DIN 6885-1 and set screw
- Part 3: Bore 120H7 mm, keyway to DIN 6885-1 P9 and set screw.
- Coupling micro-balanced G 6.3 at 1500 rpm in accordance with half parallel key standard
- Mass moment of inertia:
 $J_1 = 1.74 kgm^2$
 $J_2 = 1.74 kgm^2 + 15 kgm^2 = 16.74 kgm^2$
- Weight:
 $m = 25.8 kg + 149 kg = 174.8 kg$

Article no.: 2LC0131-4AH99-0NA0-Z L1U+M1S+W02+Y95
Plain text to Y95: G=6.3;n=1500rpm

¹⁾ To identify complete item numbers specifying the available finish boring options and – if necessary – further order options, please use our configurators on flender.com.

²⁾ For the available DB · BB brake disk dimensions, please refer to the product configurator on flender.com.

↗ For online configuration on flender.com, click on the item no.

TYPE RWB

with brake drum to DIN 15431

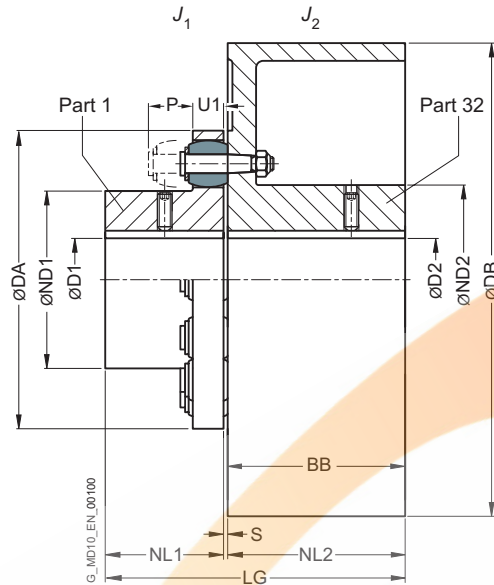

8

Size	Rated torque buffer 80 ShoreA T_{KN} Nm	Speed n_{Kmax} rpm	Dimensions in mm											Mass moment of inertia		Article no. ¹⁾	Weight m kg	
			Bore with keyway DIN 6885-1				DA	ND1	ND2	NL1	NL2/BB	S	DB	LG	J_1 kgm ²			J_2 kgm ²
			D1	D2	min.	max.												
144	500	4800	-	48	-	55	144	76	84	55	75	3	200	133	0.004	0.04	2LC0130-3AC	9.4
162	750	3800	-	55	-	60	162	85	92	60	95	3.5	250	158.5	0.007	0.11	2LC0130-4AC	17
178	950	3800	-	70	-	70	178	102	108	70	95	3.5	250	168.5	0.013	0.12	2LC0130-5AC	19
		3000	-	70	-	70	178	102	108	70	118	3.5	315	191.5			0.31	2LC0130-5AC
198	1300	3800	-	80	-	80	198	120	128	80	95	3.5	250	178.5	0.021	0.13	2LC0130-6AC	23
		3000	-	80	-	80	198	120	128	80	118	3.5	315	201.5			0.32	2LC0130-6AC
228	2200	2400	-	90	-	90	228	129	140	90	150	3.5	400	243.5	0.036	1	2LC0130-7AC	53
		2400	-	100	38	100	252	150	160	100	150	3.5	400	253.5			0.068	1
252	2750	1900	-	100	38	100	252	150	160	100	190	3.5	500	293.5	0.068	2.8	2LC0130-8AC	92
		1900	-	100	38	100	252	150	160	100	190	3.5	500	293.5			2.8	2LC0130-8AC
285	4300	1500	48	110	48	110	285	164	175	110	236	4.5	630	350.5	0.13	7.8	2LC0131-0AC	156
		1500	48	110	48	110	285	164	175	110	236	4.5	630	350.5			7.9	2LC0131-1AC
320	5500	1500	55	120	55	120	320	180	192	125	236	4.5	630	365.5	0.22	13.9	2LC0131-1AC	215
		1300	55	120	55	120	320	180	192	125	265	4.5	710	394.5			8.1	2LC0131-2AC
360	7800	1500	65	130	65	130	360	200	210	140	236	4.5	630	380.5	0.4	14	2LC0131-2AC	189
		1300	65	130	65	130	360	200	210	140	265	4.5	710	409.5			14	2LC0131-2AC

Configurable variants ¹⁾

- ØD1 Without finished bore
With finished bore
- ØD2 Without finished bore
With finished bore

Note

- For dimensions U1 and P, see type RWN on Page 8/8.
- Weight and mass moments of inertia apply to maximum bore diameters.
- The article numbers apply to standard buffers of NBR material in the 80 ShoreA variant; the article number for alternative buffer types is available on request.

Ordering example

- RUPEX RWB coupling, size 252
- Part 1: Bore 48H7 mm, keyway to DIN 6885-1 and set screw
- Part 3: 500 x 190, bore 42H7 mm, keyway to DIN 6885-1 P9 and set screw.
- Coupling micro-balanced G 6.3 at 1500 rpm in accordance with half parallel key standard

Article no.: 2LC0130-8AC99-0FA0-Z L1B+M0X+W02+Y95
Plain text to Y95: G=6.3;n=1500rpm

¹⁾ To identify complete item numbers specifying the available finish boring options and – if necessary – further order options, please use our configurators on flender.com.

➤ For online configuration on flender.com, click on the item no.

TYPE RBS

with brake drum to DIN 15431

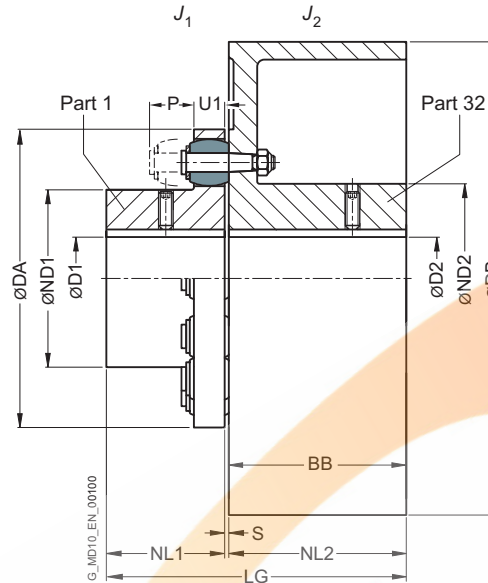

Size	Rated torque		Speed n_{kmax} rpm	Dimensions in mm											Mass moment of inertia		Article no. ²⁾	Weight m kg	
	buffer 90 ShoreA $T_{KN}^{1)}$	buffer 80 ShoreA T_{KN}		Bore with keyway DIN 6885-1		DA	ND1	ND2	NL1	NL2/ BB	S	DB	LG	J_1	J_2				
	Nm	Nm		min.	max.	min.	max.	min.	max.	min.	max.	min.	max.	kgm ²	kgm ²				
144	650	500	7800	-	55	-	60	144	76	84	55	75	3	200	133	0.004	0.04	2LC0130-3AD	10
162	950	750	6900	-	60	-	65	162	85	92	60	95	3.5	250	158.5	0.007	0.13	2LC0130-4AD	18
178	1200	950	6300	-	75	-	75	178	102	108	70	95	3.5	250	168.5	0.014	0.13	2LC0130-5AD	22
			5500	-	75	-	75	178	102	108	70	118		315	191.5		0.34	2LC0130-5AD	30
198	1700	1300	5600	-	90	-	85	198	120	128	80	95	3.5	250	178.5	0.020	0.14	2LC0130-6AD	26
			5500	-	90	-	85	198	120	128	80	118		315	201.5		0.35	2LC0130-6AD	35
228	2850	2200	4300	-	95	-	95	228	129	140	90	150	3.5	400	243.5	0.036	1.1	2LC0130-7AD	60
252	3550	2750	4300	-	110	38	110	252	150	160	100	150	3.5	400	253.5	0.066	1.1	2LC0130-8AD	67
			3400	-	110	38	110	252	150	160	100	190		500	293.5		3.1	2LC0130-8AD	102
285	5600	4300	3400	-	120	48	110	285	164	175	110	190	4.5	500	304.5	0.12	3.1	2LC0131-0AD	114
			2700	48	120	48	110	285	164	175	110	236		630	350.5		8.5	2LC0131-0AD	170
320	7150	5500	2700	-	130	55	125	320	180	192	125	236	4.5	630	365.5	0.23	8.6	2LC0131-1AD	185
			2400	55	130	55	125	320	180	192	125	265		710	394.5		14.8	2LC0131-1AD	230
360	10000	7800	2700	-	145	65	135	360	200	210	140	236	4.5	630	380.5	0.4	8.9	2LC0131-2AD	208
			2400	65	145	65	135	360	200	210	140	265		710	409.5		15.1	2LC0131-2AD	253

Configurable variants ²⁾

- ØD1 Without finished bore
With finished bore
- ØD2 Without finished bore
With finished bore

Note

- For dimensions U1 and P, see type RWS on Page 8/10.
- Weight and mass moments of inertia apply to maximum bore diameters.
- The article numbers apply to standard buffers of NBR material in the 80 ShoreA variant; the article number for alternative buffer types is available on request.

¹⁾ T_{Kmax} is given in the specifications on Page 8/6.
 T_{KW} is determined from the specifications given on Page 8/6.

Ordering example

- RUPEX RBS coupling, size 252
- Part 1: Bore 48H7 mm, keyway to DIN 6885-1 and set screw
- Part 3: 500 x 190, bore 42H7 mm, keyway to DIN 6885-1 P9 and set screw
- Coupling micro-balanced G 6.3 at 1500 rpm in accordance with half parallel key standard

Article no.: 2LC0130-8AD99-0FA0-Z L1B+M0X+W02+Y95
Plain text to Y95: G=6.3;n=1500rpm

²⁾ To identify complete item numbers specifying the available finish boring options and – if necessary – further order options, please use our configurators on flender.com.

↗ For online configuration on flender.com, click on the item no.

SPARE AND WEAR PARTS

Buffers and pins

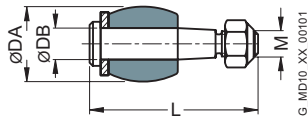

Sizes 105 to 400

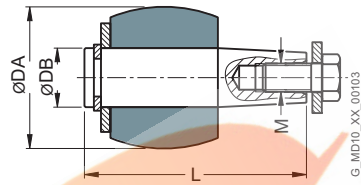

Sizes 710 to 2000

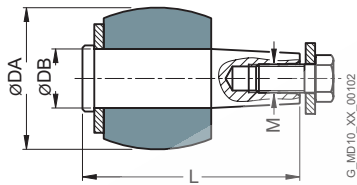

Sizes 450 to 630

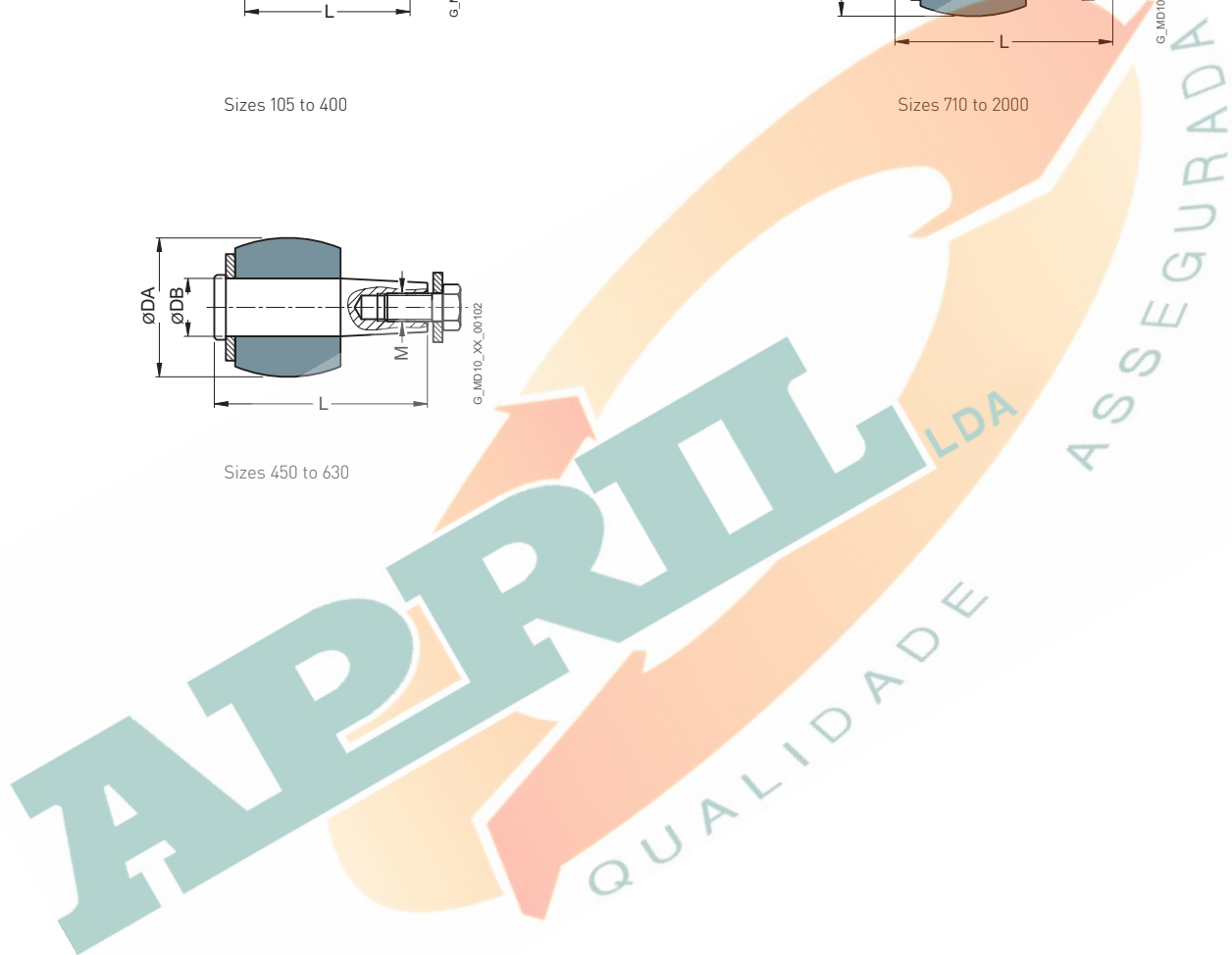

Size	Marking	Number per set	Dimensions				Article No. for a set of buffers [Buffer Perbunan 80ShoreA]	Weight m kg	Article No. for a set of pins [Pin complete, incl. fasteners]	Weight m kg
			DA mm	DB mm	L mm	M				
105	105	8	20	8	45	M6	2LC0130-1WA00-0AA0	0.043	2LC0130-1WB00-0AA0	0.14
125	125	8	24	10	53.5	M8	2LC0130-2WA00-0AA0	0.098	2LC0130-2WB00-0AA0	0.28
144	125	10	24	10	53.5 59.5	M8	2LC0130-3WA00-0AA0	0.12	2LC0130-3WB00-0AA0 ASE36074885	0.35 0.4
162	162	9	30	12	64.5 67.5	M10	2LC0130-4WA00-0AA0	0.17	2LC0130-4WB00-0AA0 ASE36074964	0.57 0.6
178	162	10	30	12	64.5 67.5	M10	2LC0130-5WA00-0AA0	0.19	2LC0130-5WB00-0AA0 ASE36075371	0.65 0.67
198	162	12	30	12	64.5 67.5	M10	2LC0130-6WA00-0AA0	0.23	2LC0130-6WB00-0AA0 ASE36075396	0.76 0.8
228	228	11	40	16	79	M12	2LC0130-7WA00-0AA0	0.42	2LC0130-7WB00-0AA0	1.4
252	228	12	40	16	79	M12	2LC0130-8WA00-0AA0	0.45	2LC0130-8WB00-0AA0	1.5
285	285	11	48	20	98	M16	2LC0131-0WA00-0AA0	0.81	2LC0131-0WB00-0AA0	2.5
320	285	12	48	20	98	M16	2LC0131-1WA00-0AA0	0.88	2LC0131-1WB00-0AA0	2.8
360	360	10	64	25	123	M18	2LC0131-2WA00-0AA0	1.6	2LC0131-2WB00-0AA0	4.4
400	360	14	64	25	123	M18	2LC0131-3WA00-0AA0	2.2	2LC0131-3WB00-0AA0	6.1
450	450	12	78	32	123	M16	2LC0131-4WA00-0AA0	3.5	2LC0131-4WB00-0AA0	11
500	450	14	78	32	123	M16	2LC0131-5WA00-0AA0	4	2LC0131-5WB00-0AA0	13
560	560	12	101	42	158	M20	2LC0131-6WA00-0AA0	7.1	2LC0131-6WB00-0AA0	25
630	560	14	101	42	158	M20	2LC0131-7WA00-0AA0	8.3	2LC0131-7WB00-0AA0	29
710	710	14	120	50	185.5	M24	2LC0131-8WA00-0AA0	14	2LC0131-8WB00-0AA0	49
800	710	16	120	50	185.5	M24	2LC0132-0WA00-0AA0	16	2LC0132-0WB00-0AA0	56
900	900	16	136	55	207.5	M24	2LC0132-1WA00-0AA0	24	2LC0132-1WB00-0AA0	71
1000	900	18	136	55	207.5	M24	2LC0132-2WA00-0AA0	27	2LC0132-2WB00-0AA0	80
1120	1120	18	155	60	232.5	M30	2LC0132-3WA00-0AA0	41	2LC0132-3WB00-0AA0	110
1250	1120	20	155	60	232.5	M30	2LC0132-4WA00-0AA0	45	2LC0132-4WB00-0AA0	125
1400	1400	20	175	70	274	M30	2LC0132-5WA00-0AA0	65	2LC0132-5WB00-0AA0	185
1600	1400	24	175	70	274	M30	2LC0132-6WA00-0AA0	78	2LC0132-6WB00-0AA0	225
1800	1800	22	200	80	327	M36	2LC0132-7WA00-0AA0	115	2LC0132-7WB00-0AA0	320
2000	1800	26	200	80	327	M36	2LC0132-8WA00-0AA0	135	2LC0132-8WB00-0AA0	380

Note

- The buffers of RUPEX couplings are wear parts.
The service life depends on the operating conditions.

¹⁾ For types RWB/RBS with brake disk BB = 30 only